

OPERATING
ALIGNMENT & SERVICING
INSTRUCTIONS FOR

MODEL S14 Sky Chief

the hallicrafters *inc.*

CHICAGO U.S.A.

THE SKY-CHIEF - model S-14

Amateur Communication Receiver

The new 1937 Sky-Chief is a 3 band, 7 tube superheterodyne receiver covering the following frequency ranges:

Band No. 1 - 540 KC to 1,700 KC
Band No. 2.- 1.68 MC to 5.45 MC
Band No. 3 - 5.30 MC to 18.0 MC

The knob marked "Bands" will indicate which set of coils is being tuned. The illuminated dial is accurately calibrated in megacycles on all three of the bands. Bands No. 1 and No. 3 are on the top half of the dial with Band No. 2 on the lower half. You will notice there are two pointers on the dial; the white pointer which moves only through an arc of 180 degrees, or half the dial, and the red pointer which makes many complete revolutions when the receiver is tuned across each range. This small "sweep-hand" points to numbers around the edge of the dial and is of great help in accurately logging between the larger numbers.

- No. 1 Band goes through the American Broadcast range and up to 1.70 MC. You will notice that on this band the final zero has been purposely omitted in the calibration. No difficulty should be experienced in tuning for a station of known frequency. For instance, if WLW, the frequency of which is 700 KC, is being tuned in, put the receiver on Band No. 1 and the white pointer on 70 to get this station.
- No. 2 Band covers from 1.68 MC to 5.45 MC. The lower half of the white pointer is the part to be used in tuning on this band. You will receive on this range 160 and 80 meter amateur code and phone signals, experimental high fidelity broadcasts, aircraft and police transmissions.
- No. 3 Band covers from 5.30 MC to 18.0 MC. This range will prove the most interesting because of the probability of receiving signals over great distances. On this band it is possible to receive short wave broadcasts on four different channels, two amateur bands, and code and phone signals from various other services. The frequencies on which foreign and local broadcasts are most likely to be received are: 6 MC (49 meters), 9.5 MC (31 meters), 12 MC (25 meters), and 15.8 MC (19 meters). The 7 MC (40 meters) amateur code, and the 14 MC (20 meter) amateur code and phone bands should also provide interesting DX reception.

TO OPERATE

After removing the receiver from the shipping case, inspect it carefully to see if any damage has been done in shipment. Should such be the case, immediately file a claim with the transportation company.

This receiver, unless otherwise specified, operates on 60 cycle, 110 volt, alternating current.

See that all the tubes are in their sockets and that no shields or caps have been jarred loose. The tube line-up in this receiver is as follows:

6D6 - RF Stage-preselector.
6A7 - Combined 1st Detector and Signal Frequency Oscillator.
6F7 - I.F. Amplifier and Beat Oscillator.
75 - 2nd. Detector and 1st stage of audio.
6B5 - 2nd Stage of Audio.
6G5 - Tuning indicator
80 - Full-wave rectifier

In the lower left hand corner of the back of the receiver, will be found three wires coming out of the chassis. These wires which are colored red, yellow and black, are the antenna and ground connections and should be connected as follows:

If a conventional flat-top and lead-in type of antenna is used, connect the lead-in to the red wire.

If a doublet antenna is used, connect the two wires of the doublet lead-in to the red and yellow wires.

In either of the above instances, the black wire can be connected to a water pipe, radiator or other ground if in so doing the performance of the receiver is improved.

It is suggested that a little experimenting be done with the location, length and type of antenna to realize the best results.

For satisfactory over all operation, a length of soft drawn enameled 14 gauge copper wire 100' long is recommended.

Plug the cord on the receiver into the power socket. Now turn the control marked "Tone" to the right. When this is done the dial will be illuminated showing that the set is turned on. Be sure that the switch marked "Send-Receive" is in the "Receive" position so that all the tubes will have plate voltage. With the receiver in the broadcast range (Band No. 1) and the "R.F." and "A.F. Gain" controls well advanced to the right, tune across the dial by turning the knob marked "Main Tuning". If the receiver is operating properly numerous broadcast signals should be heard. It is suggested that most of your operating be first done on Band No. 1 until you have completely familiarized yourself with the way the receiver tunes.

The same control with which you turned on the receiver is also the "Tone" control. Turning it as far as it will go to the right will emphasize the high notes, while turning it as far as it will go to the left without turning the receiver off will emphasize the bass response.

You probably have noticed the behavior of the "Tuning Indicator, while tuning across the broadcast band. The Indicator visually shows a station is perfectly tuned-in when the "eye" is closed as much as it can be by the strength of the signal being received.

The control marked "R.F. GAIN" controls the sensitivity of the receiver. This control is in the cathode circuit of the R.F. and I.F. stages.

The control marked "A.F. GAIN", controls the volume of the receiver. This is done by varying the input to the grid of the triode section of the 75, 2nd detector and first stage of audio tube.

You will find, especially on the higher frequencies, that the signal to noise ratio can be greatly improved by properly adjusting the "R.F." and "A.F. GAIN" controls until the signal is most clearly received at the desired volume.

It is suggested that the switch marked "A.V.C." be left in the "ON" position when receiving voice transmissions. With the switch in this position the "R.F. GAIN" control should be turned as far as it will go to the right, or the position of maximum gain. If the maximum sensitivity of the set is to be desired the "A.V.C." switch can be left in the "OFF" position and the sensitivity of the set manually controlled by the "R.F. GAIN" control. When the receiver operates without automatic volume control there will be a tendency for it to overload and distort on extremely strong signals.

For the reception of C.W. signals, the "BFO" switch must be in the "ON" position. Adjustment of the "Pitch" control will vary the beat note to a tone most satisfactory to the operator. When the receiver is being used for the reception of C.W. signals it is suggested that the "AVC" switch be in the "OFF" position. Using the receiver with the beat oscillator on will prove helpful in locating phone stations. Once the station has been found the oscillator should be turned off or a continuous whistle will result.

The switch marked "SEND-RECEIVE" when in the "SEND" position, makes the receiver temporarily inoperative without turning the set completely off. This switch is useful for transmitting amateurs who wish to have the receiver dead while sending.

When head-phone operation is desired, use is made of the jack marked "PHONES." Head phones of 2000 ohms or higher will work most satisfactorily with this receiver. When head-phone plug is inserted in this jack the loud speaker in the receiver is cut out of the circuit. There is no DC on the headphone jack eliminating the possibility of shock to the operator.

The Hallicrafters, Inc., reserve the right to make changes in design or add improvements to instruments manufactured by them, without incurring any obligation to install the same in any instrument previously purchased.



**THE SKY CHIEF — A New 7-Tube Superheterodyne
with excellent performance at an attractive price**

The Sky Chief is designed with all the latest features usually found only on much higher priced sets. Tunes from 17.6 MC to 540 KC and is equipped with all the features and controls so desirable to critical operators. Good sensitivity and selectivity.

- Single Stage 465 K.C. Iron Core I.F.
- 17.6 to 540 K.C. in three bands.
- Variable Beat Oscillator.
- Automatic Volume Control.
- Positive 3 Band Selector Switch.
- Mechanical Band Spread.
- Built-in Speaker and Power Pack.

The new 1937 Sky-Chief

is a 3 band, 7 tube superheterodyne

receiver covering the following frequency ranges:

BAND 1 - 540 to 1700 KC

BAND 2 - 1.68 to 5.45 MC

BAND 3 - 5.3 to 18 MC

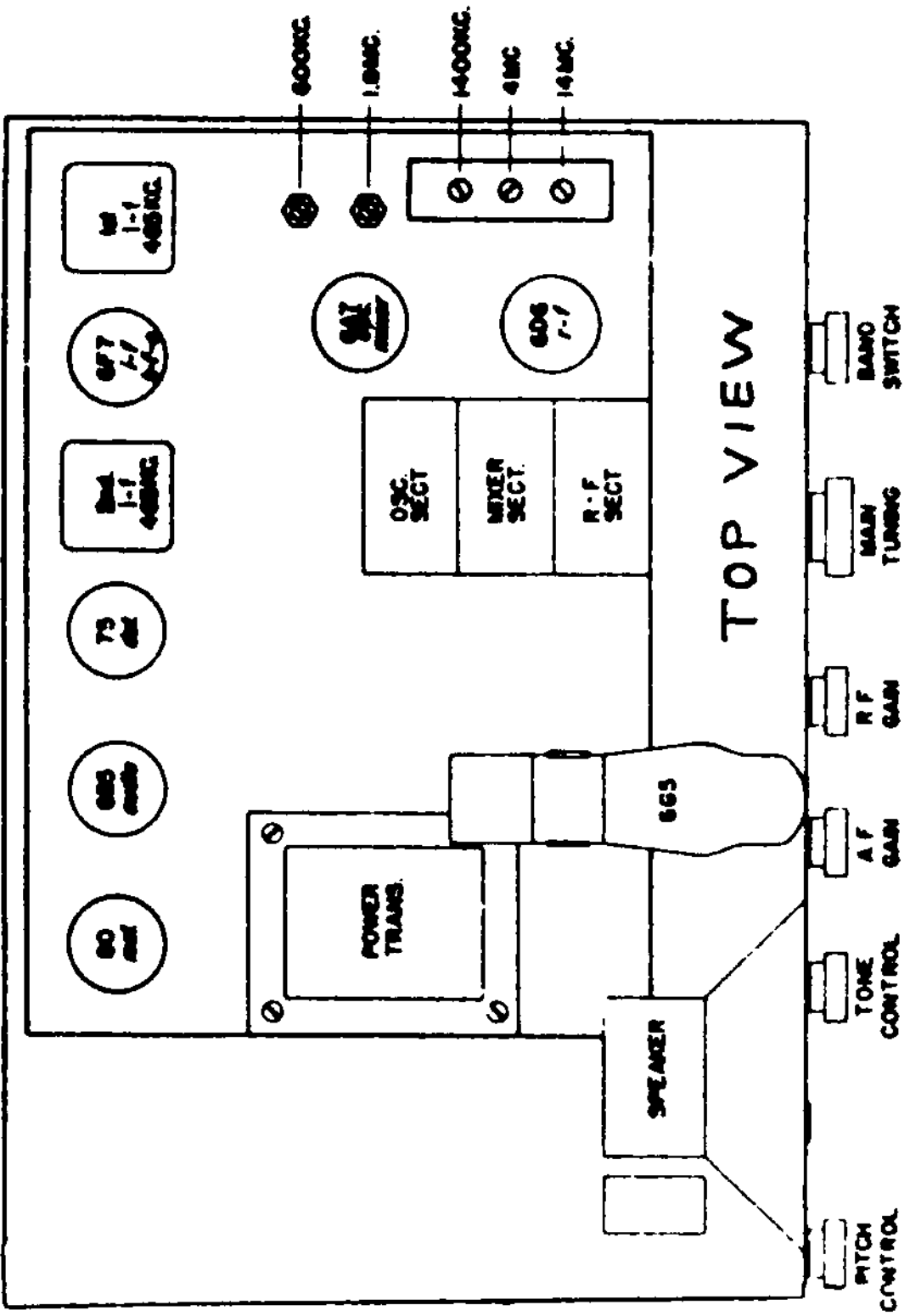

CONVENTIONAL
ALIGNMENT-

BAND 1 - 540 to 1700 KC, Trim at 1400 KC, Pad at 600 KC

BAND 2 - 1.68 to 5.45 MC, Trim at 4000 KC, Pad at 1800 KC

BAND 3 - 5.3 to 18 MC, Trim at 14000 KC, Pad not required.

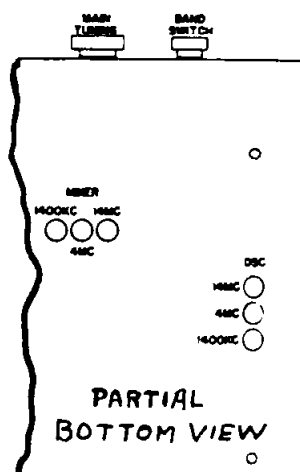

ALIGNMENT PROCEDURE FOR THE SKY-CHIEF MODEL S-14

I. F. ALIGNMENT

- 1 AFTER REMOVING THE GRID CAP OF THE 6A7 TUBE CONNECT THE SIGNAL GENERATOR TO THIS TUBE; GROUND OF THE GENERATOR TO CHASSIS.
- 2 SET GENERATOR TO 465 KC; SET TUNING GANG TO MINIMUM CAPACITY.
- 3 HAVE BAND SWITCH SET FOR #1 BAND.
- 4 LEAVE AF AND RF CONTROLS ON FULL; A.V.C. SWITCH IN "OFF" POSITION.
- 5 WITH AN INSULATED SCREW DRIVER ADJUST THE TRIMMERS ON THE 1ST AND 2ND I.F. TRANSFORMERS UNTIL MAXIMUM SIGNAL STRENGTH IS SECURED.
IF AN OUTPUT METER IS AVAILABLE CONNECT TO VOICE COIL LEADS OF THE SPEAKER OR FROM SCREEN TO PLATE OF THE 42 TUBE THROUGH A SUITABLE COUPLING CONDENSER.

R. F. ALIGNMENT

- 1 REMOVE GENERATOR FROM 6A7 TUBE; REPLACE GRID WIRE TO TUBE CAP; CONNECT GENERATOR WITH A 400 OHM RESISTOR IN SERIES TO ANT (RED) WIRE.
- 2 BE SURE BAND SWITCH IS ON #1 BAND.
- 3 SET GENERATOR AND RECEIVER TO 1400 KC.
- 4 ADJUST 1400 KC OSCILLATOR AND MIXER TRIMMERS LOCATED ON THE BOTTOM OF THE CHASSIS FOR MAXIMUM SIGNAL. NEXT ADJUST THE 1400 KC ANTENNA LOCATED ON THE TOP OF THE CHASSIS FOR MAXIMUM SIGNAL.
- 5 SET GENERATOR AND RECEIVER TO 600 KC
- 6 ADJUST 600 KC PAD LOCATED ON THE TOP OF THE CHASSIS FOR MAX SIGNAL.
- 7 TURN BAND SWITCH TO #2 BAND AND GO THROUGH THE ABOVE PROCEDURE FOR THE TWO FREQUENCIES INDICATED FOR THIS BAND - 4MC BELOW THE CHASSIS 1.8MC ON THE TOP.
- 8 TURN BAND SWITCH TO #3 BAND AND GO THROUGH THE ABOVE PROCEDURE - 14MC BELOW THE CHASSIS, AND THEN CHECK 6MC WITH THE GENERATOR. THERE IS NO LOW FREQUENCY PAD ON THIS BAND. 6MC SHOULD FALL PLUS OR MINUS 1/2 TO 1 DIVISION NEAR 6MC WITH NO FURTHER ADJUSTMENTS.

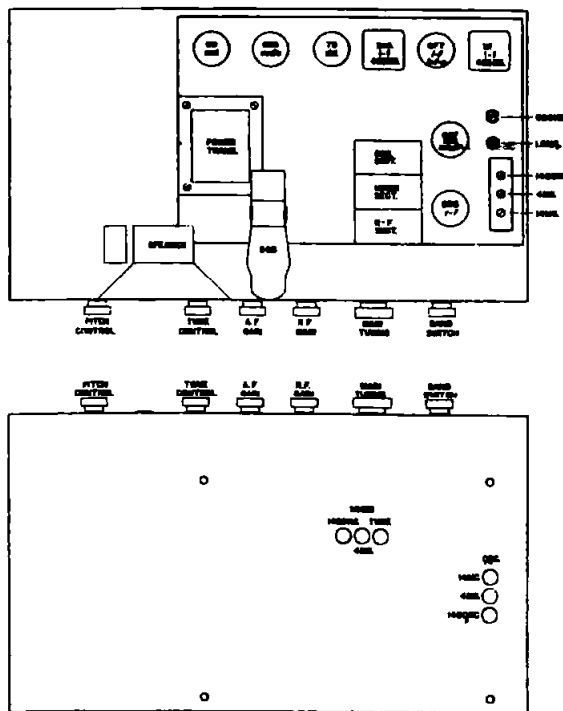

SYMBOLS MODEL S-14 - SKY-CHIEF

Resistors

Condensers

Resistors				Condensers					
No	2 Value Chms	Watts Rating	Tol.	Parts No.	No.	Value Mfd	Rating Volts	Tol.	Part No.
R1	100M	1/3	10%	2292	C1	450MM			48-015
R2	200	1/3	10%	2214	C2	450MM			48-015
R3	20M	1	20%	2070	C3	450MM			48-015
R4	100M	1/3	20%	2093	C4	.003 Mica		5%	4314
R5	10M	1	20%	2061	C5	1230 MM			4413
R6	50M	1/3	20%	2084	C6	440MM			4409
R7	250	1/3	10%	2217	C7	.01	200	20%	4100
R8	10M	RF Gain Cont.		2515	C8	.01	200	20%	4100
R9	200	1/3	10%	2214	C9	.1	200	20%	4106
R10	100M	1/3	20%	2093	C10	.05	400	20%	4105
R11	20M	1		2070	C11	.1	200	20%	4106
R12	100M	1/3	20%	2093	C12	.002 Mica			4013
R13	25M	1/3	20%	2075	C13	.0001 Mica			4004
R14	1 meg	1/3	20%	2108	C14	.1	200	20%	4106
R15	500M	Volume Cont.		2516	C15	.00025 Mica			4007
R16	100	1/3	20%	2009	C16	.01	400	20%	4101
R17	500M	1/3	20%	2102	C17	.1	400	20%	4107
R18	250M	1/3	20%	2099	C18	.0005 Mica			4009
R19	500M	Tone Cont w/switch-	2517		C19	.0001 Mica			4001
					C20	.0005 Mica			4009
					C21	.05	200	20%	4104
					C22	.1	200	20%	4106
					C23	.01	400	20%	4101
					C24	.01	400	20%	4101
					C25	.002 Mica			4013
					C26	.01	600	20%	4502
					C27	.01	600	20%	4502
					C28	12 mfd			4212
					C29	8 mfd			4209
					C30	.000025 mfd Mica			4024
					C31	.00005 mfd Mica			4023
					C32	.05	200	20%	4104

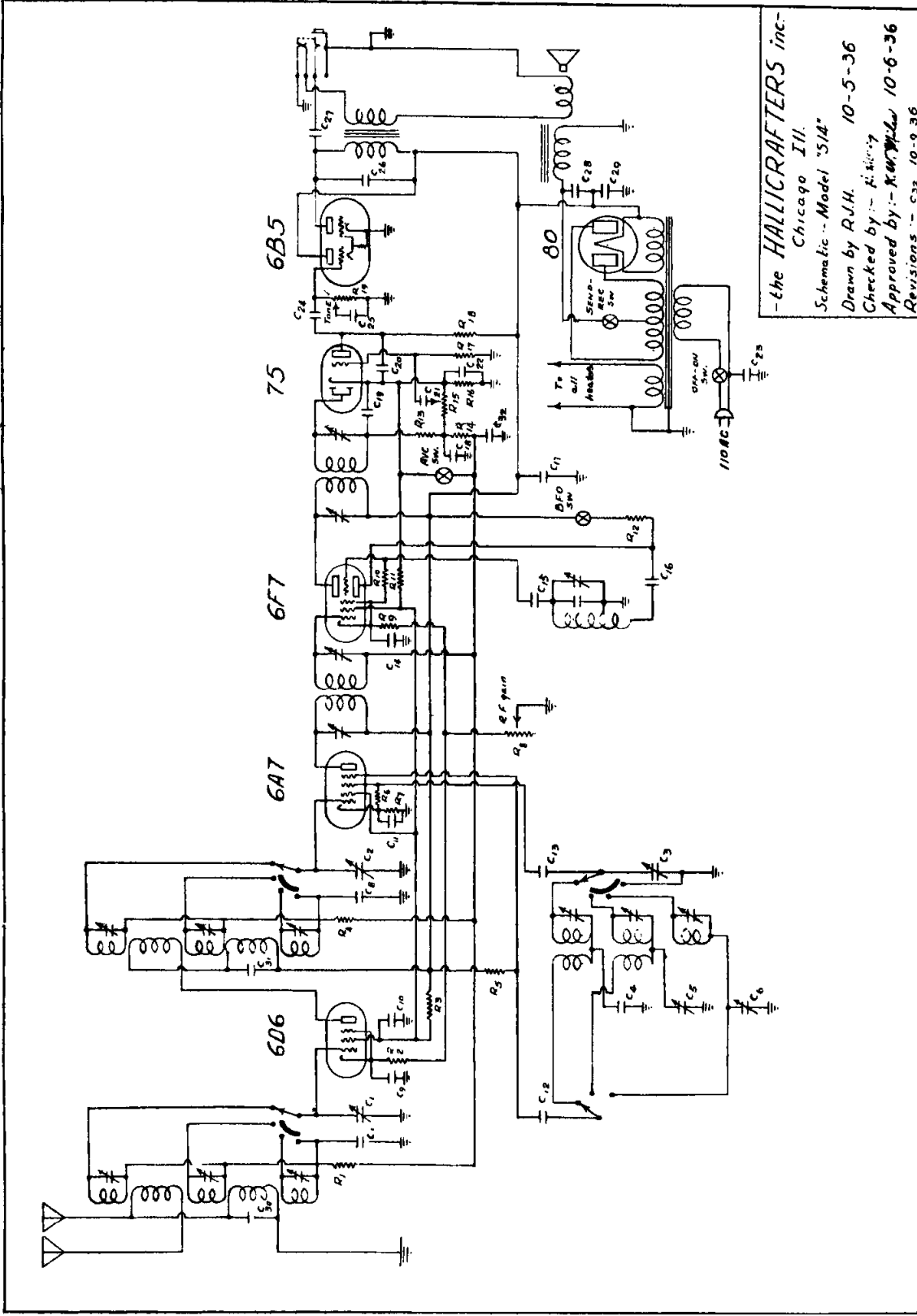

-the HALLICRAFTERS inc-
 Chicago Ill.
 Schematic - Model "514"
 Drawn by R.J.H. 10-5-36
 Checked by - K.M.P. 10-6-36
 Approved by - K.M.P. 10-6-36
 Revisions - C32 10-9-36